

CLEARWAY

S | SERIES

Introducing the S-Series® Clearway™ Wheelchair Lift

Ricon S-Series Clearway lift
elevate the industry standard
for excellence in safe and
reliable wheelchair lifts.



ELEVATING THE INDUSTRY STANDARD FOR EXCELLENCE

The S-Series Clearway offers a fully automatic Clearway™ split platform, featuring the security of the industry-leading Ricon Safety Zone. Compact and simple to operate, the innovative S-Series Clearway lift design provides the passenger with safety and peace of mind, assuring you have the highest value accessibility solution available.

PERFORMANCE, RELIABILITY AND VALUE

Ricon S-Series Clearway wheelchair lifts formed the catalyst, setting the industry standard for performance, value and ease of use. These innovative design features include:

- Exclusive split-platform design
- The driver's line of sight is unobstructed for optimum safety
- Non-intrusive space-saving footprint
- Lightweight, compact design
- Easy operation and maintenance
- Durable design for long lift life
- Multiple dimension options providing versatility between customers
- Interlocking passenger safety restraint belt
- 5 Year Limited Warranty
- ADA Compliant



ADVANCED RICON LIFT TECHNOLOGY FEATURES RELIABLE PERFORMANCE AND USER-FRIENDLY DESIGN

Features:

- Industry-leading Ricon Safety Zone: Combines front and rear roll stops and handrails, secures passengers during lift operation.
- Simple and reliable operation provides convenient vehicle access for wheelchairs and scooters.
- Powerful hydraulic pump assures smooth, stable operation.
- Pre-lubricated bearings at all major pivot points for long-term durability.
- All steel construction with high gloss, polyester powder coat finish resists corrosion.
- Standard lifts rated at 364kg.
- ADA regulation compliant.
- Available with Ski Wheels.
- 5-year Limited Warranty.
- Exclusive split-platform design folds vertically enabling clear access to vehicle interior.
- The driver's line of sight is unobstructed for optimum safety.



MANUAL BACKUP SYSTEM – hand pump mechanism provides manual lift operation in case of power loss.



AUTOMATIC INBOARD ROLL-STOP – features quiet patented Sto-Loc self-adjusting mechanism with built in fail safe features.



OUTER ROLL-STOP SWITCH – limits platform travel if not locked into position.



TIGHTER MESH NON SKID PLATFORM – for greater rigidity and improved performance.

OCCUPANT RESTRAINT BELT SYSTEM – Patented fully interlocked Ricon occupant restraint belt system. Combines with dual handrails, inner and outer roll-stop barriers and side rails for industry-leading passenger security.

ANTIMICROBIAL COATING – to handrails can be provided as an optional extra.

SKI WHEELS – can be provided as an optional extra.

LIFT WEIGHTS – between 141-173kg.

EXCLUSIVE SPLIT-PLATFORM – allowing unobstructed access upon exit and entry whether or not the lift is deployed.

S-SERIES™ CLEARWAY™ LIFT

Power..... electro-hydraulic (power-up/gravity-down)
 Pump rating@12 VDC 65A avg/cycle, 1250psi
 Pump rating@24 VDC 32.5A avg/cycle, 1250psi
 Hydraulic cylinders..... 2ea, 38mm dia
 Rated load capacity 364 kgs
 Manual backup (up)..... hand pump
 Manual backup (down)..... pressure release valve
 Lift weight..... 141–173 kgs

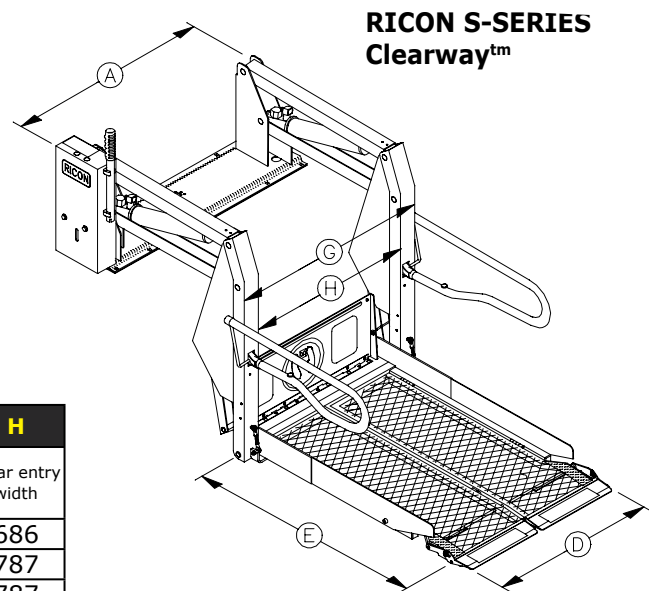
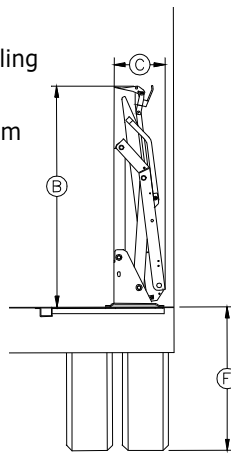

DIMENSIONS – mm	A	B	C	D	E	F	G	H
MODEL	Stationary frame width	Height (folded)	Installation depth (folded)	Usable platform width	Usable platform length	Floor-to-ground travel	Traveling frame width	Clear entry width
S1132-P	1041	1029	495	660	965	686	851	686
S1133-P	1143	1029	456	762	965	686	953	787
S1231-P	1143	1029	546	762	1067	787	953	787
S2030	1143	1397	546	762	1219	1067	953	787
S2034	1143	1778	546	762	1600	1067	953	787
S2035	1143	1397	356	762	1219	1067	953	787
S2036	1193	1397	572	813	1300	1067	1003	838
S5030	1143	1467	546	762	1219	1219	953	787

National Importer and Distributor



156 Beringarra Ave, MALAGA WA 6090
 email: kevrek@kevrek.com.au
 website: www.kevrek.com.au
 Ph: (08) 9248 5922 Fax: (08) 9248 5966

Copyright 2010 Ricon Corporation. Ricon, S-Series, K-Series, Clearway, Klearvue and Sto-Loc are trademarks of Ricon Corporation. Ricon Corp. and Kevrek Australia reserves the right to discontinue models or options at any time or change specifications, materials, equipment, or pricing without notice and without incurring obligation.

