



***Lifting 550kg at 1m, the K550 provides the perfect lightweight and compact lifting solution.***



***550Kg Lifting Capacity At 1M  
2.5 Metre Full Extension  
225Kg Lifting Capacity At 2.5M  
Emergency Stop  
Slew Operator Protection  
Hose Burst Protection  
Valve Control Guard  
Load Indicator  
Compliance - AS1418-11-2014***



***Flexible Mounting Options  
Purposely built for the Australian Market  
National and International Dealer Network  
Specialised Attachments Available  
Proudly Australian Made  
2 Year Warranty  
5 Year Limited Warranty***



# KEVREK 550s CRANE SPECIFICATIONS

## TECHNICAL FEATURES:

|   |   |
|---|---|
| Capacity Class  | 0.56Tm (5.49 kNm)                               |
| Maximum Lift Capacity                                 | 550kg @ 1.035m Radius                           |
| Standard Outreach                                     | 2.52m   |
| With Additional Boom                                  | N/A   |
| Lifting Height Above Base Standard                    | 3.25m   |
| With Additional Boom                                  | N/A   |
| Outreach/Lifting Capacity                             | 1.03m - 550kg<br>1.78m - 330kg<br>2.52m - 225kg |
| Slewing Torque  | 1.5 kNm   |
| Slewing Angle   | 290°  |
| Pump Capacity   | 4.9 > 7.0l/min                                  |
| Oil Tank Volume                                       | 3.0l  |
| Working Pressure                                      | 1750 PSI (120 BAR)                              |
| Power Consumption                                     | 12 volt - 50 > 150 amp<br>24 volt - 50 > 90 amp |
| Weight Inc/Power Pack And Oil                         | 125kg   |
| Weight - Manual Leg C/W Motor Mount and Storage Mount | 14kg  |
| Height Folded   | 1057mm  |

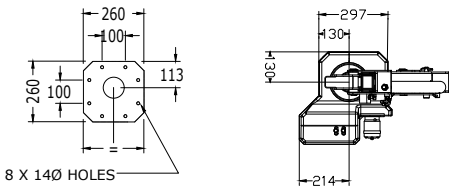
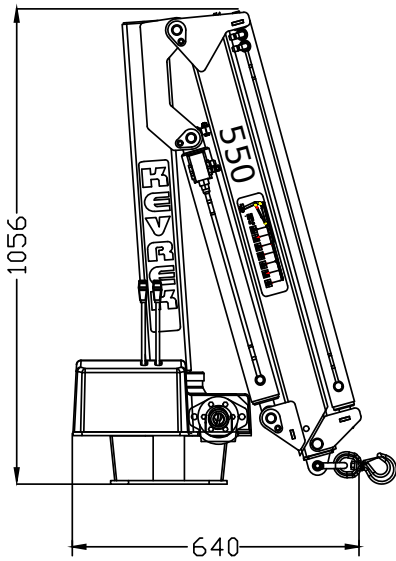

MOUNTING BASE PATTERN

## Options:

- Radio Remote Control
- Manual Swing Up Leg
- Hydraulic Leg
- Multiple Function Pendant Control

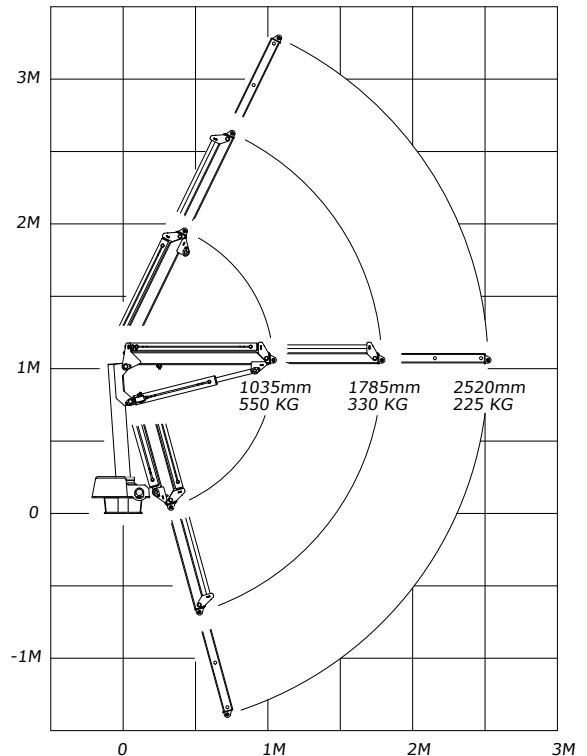
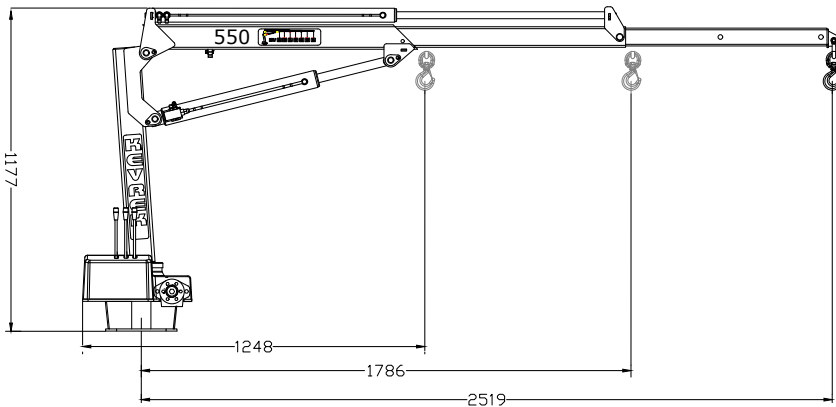

The Australian Lifting Solution



156 Beringarra Ave, MALAGA WA 6090  
 email: kevrek@kevrek.com.au  
 website: www.kevrek.com.au  
 Ph: (08) 9248 5922 Fax: (08) 9248 5966

Kevrek Australia reserves the right to discontinue models or options at any time or change specifications, materials, equipment, or pricing without notice and without incurring obligation.