

CARGO LIFT

Introducing the Commercial RICON Cargo Lift™

A simple and effective
goods lifting solution
suitable for most
Light Commercial Vehicles.

Raising the standards
and offering you peace
of mind when it comes
to manual handling.



**THE INDUSTRY STANDARD FOR OVERALL
PERFORMANCE, RELIABILITY & VALUE**

Ricon's 40 years of experience in the passenger lift market has now been applied to the commercial market to produce one of today's most simple cost effective goods lifting solutions, suitable for fitment to most Light Commercial Vehicles.

Ricon's comprehensive quality control systems ensure that the same exacting standards of manufacture are reproduced time after time to deliver you the safety, quality and reliability synonymous with the Ricon name.

Ricon Cargo Lifts are designed to overcome the increasing concerns of lifting excessive weight loads by individuals. Working with the Health and Safety Executive guidelines and aims for manual handling, the Ricon Cargo Lifts are the perfect partner for all your non-passenger lifting requirements.

Compact and simple to operate, the innovative Cargo Lift design provides convenient loading and unloading in non-passenger applications, parcels and luggage, helping employers to meet their risk assessment and method statement requirements set out in the Management of Health and Safety at Work Regulations 1999.



CARGO LIFT

The RICON Cargo Lift™



- Easy operation and maintenance
- Non-intrusive space-saving footprint

Features:

- Stable non-skid one piece horizontal platform.
- Pendant hand control.
- Electro hydraulic power operation.
- Automatic outer barrier.
- Simple and reliable operation provides convenient vehicle access for cargo.
- 500kg lifting weight capacity.
- Pre-lubricated bearings at all major pivot points for long-term durability.
- Built-in manual backup system in case of power loss.
- 5 - year Limited Warranty.



ADVANCED RICON LIFT TECHNOLOGY FEATURES RELIABLE PERFORMANCE AND USE-FRIENDLY DESIGN

MANUAL BACKUP SYSTEM hand pump mechanism provides manual lift operation in case of power loss.

SLIDE-OFF PUMP COVER WITH "SECUR-STOR"

BACKUP TOOL STORAGE easy access with no bolts to remove, simply push the top-mounted cover release and pull up for total access to the manual backup tool, pumping and electrical components.



If a lift is not supplied with optional roll stop subtract 134mm (5") from the stowed height and 146mm (6") from the unstable platform height.

Please note, the Cargo Lift DOES NOT meet requirements for passenger lifts and therefore they MUST NOT be used for this type of application.

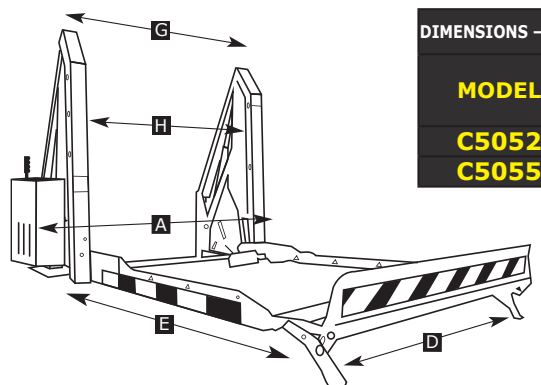

DIMENSIONS - mm		A	B	C	D	E	F	G	H
MODEL	Stationary frame width	Height (folded)	Installation depth (folded)	Usable platform width	Usable platform length	Floor-to-ground travel	Traveling frame width	Clear entry width	
C5052	1245	1320	356	864	1193	1219	1054	889	
C5055	1245	1626	356	864	1500	1219	1054	889	

National Importer and Distributor



156 Beringarra Ave, MALAGA WA 6090
 email: kevrek@kevrek.com.au
 website: www.kevrek.com.au
 Ph: (08) 9248 5922 Fax: (08) 9248 5966

Copyright 2010 Ricon Corporation. Ricon, S-Series, K-Series, Klearvue and Sto-Loc are trademarks of Ricon Corporation. Ricon Corp. and Kevrek Australia reserves the right to discontinue models or options at any time or change specifications, materials, equipment, or pricing without notice and without incurring obligation.

